

NanoSpeed™ 30dB Extinction, Low Drift 1x1 Fiber Optical Switch

1dB Loss, SMF, PMF, High Power, Bidirectional

(Protected by U.S. patent 7,403,677B1 and pending patents)



DATASHEET

[Return to the Webpage](#)

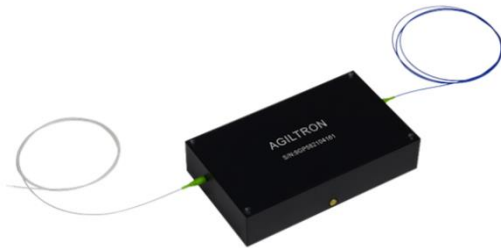

Applications

- Laser Systems
- Sensor Systems
- Instruments
- Quantum Systems

Features

- 30dB High on/off Ratio
- Solid State High Reliability
- High Speed
- Very Low Optical Loss
- High Optical Power Handling
- Minimal Transit Echoes
- Wide Operation Temperature Range
- Vibration Insensitive

The NSSI (NSS3) series of NanoSpeed™ electro-optical switches uniquely feature low optical loss and high on-off extinction of 30dB, little drift, fast response, and high optical power handling. This is achieved using drift-compensating electro-optical control technology that significantly reduces drift to achieve a high on/off ratio at high speed. It cascades several switches on a PCB board with a cover. Control is 5V TTL via an SMA signal input port, and power is 12V DC (a wall pluggable is accompanied inside the shipping box). The NS fiber-optic switch meets the most demanding reliability requirements for undersea, space, and continuous switching with a longevity of over 25 years. The switch is intrinsically bidirectional and selectable for polarization-independent or polarization-maintain by the fiber type. No optical signal loss occurs during the switching in which optical power is transferred continuously from one port to another (see graph at the end).

The Low-Drift series of Nanospeed™ devices are intended to be operated at a repetition rate >1Hz.

The NS series switches respond to a control signal with any arbitrary timing with frequency from DC up to MHz. The switch is usually mounted on a tuned driver before shipping. The electrical power consumption is related to the repetition rate at which the switch is operated.

The device may have some drift over time when operated at a zero switching rate.

The dual-stage configuration increases the extinction ratio or cross-talk value.

Specifications

Parameter	Min	Typical	Max	Unit
Center Wavelength ^[1]	650		2300	nm
Insertion Loss ^[2] 1900 – 2300nm		1.2	1.8	
Insertion Loss ^[2] 1700 – 1900nm		1	1.2	
Insertion Loss ^[2] 1260 – 1650nm	0.5	0.8	1	dB
Insertion Loss ^[2] 960 – 1100nm		1	1.8	
Insertion Loss ^[2] 650 – 950nm		1.2	2	
On/Off Ratio, Cross Talk ^[3]	25		35	dB
Durability	10 ¹⁴			cycle
PDL (SMF)		0.15	0.3	dB
PMD (SMF)		0.1	0.3	ps
ER (PMF)	18	25		dB
Insertion Loss Temperature Dependence		0.25	0.5	dB
Return Loss	45	50	60	dB
Response Time (Rise or Fall)		50	100	ns
Optical Power Handling ^[4]		0.3	20	W
Repetition Rate ^[5]	0.0001		20	kHz
Operating Temperature	-10		50	°C
Storage Temperature	-40		80	°C
Power Consumption			2	W

Notes:

[1] Operation bandwidth is ± 25 nm, approximately at 1550nm.

[2] Measured without connectors. Each connector adds about 0.25dB loss

[3] ± 25 nm, measured at 100kHz. The time gap between switching should be <10ms to avoid charge built-up at wavelengths shorter than 800nm that may degrade the on/off value.

[4] Defined at 1310nm/1550nm. For the shorter wavelength, the handling power may be reduced.

[5] Currently, only DC-100kHz is available. Higher frequency is under development

Note: The specifications provided are for general applications with a cost-effective approach. If you need to narrow or expand the tolerance, coverage, limit, or qualifications, please [click this link](#):

Warning: This is an OEM module designed for system integration. Do not touch the PCB by hand. The electrical static can kill the chips even without a power plug-in. Unpleasant electrical shock may also be felt. For laboratory use, please buy a Turnkey system.

Legal notices: All product information is believed to be accurate and is subject to change without notice. Information contained herein shall legally bind Agiltron only if it is specifically incorporated into the terms and conditions of a sales agreement. Some specific combinations of options may not be available. The user assumes all risks and liability whatsoever in connection with the use of a product or its application.

Rev 10/20/24

NanoSpeed™ 30dB Extinction, Low Drift 1x1 Fiber Optical Switch

1dB Loss, SMF, PMF, High Power, Bidirectional

(Protected by U.S. patent 7,403,677B1 and pending patents)



DATASHEET

Mechanical Dimensions (mm)

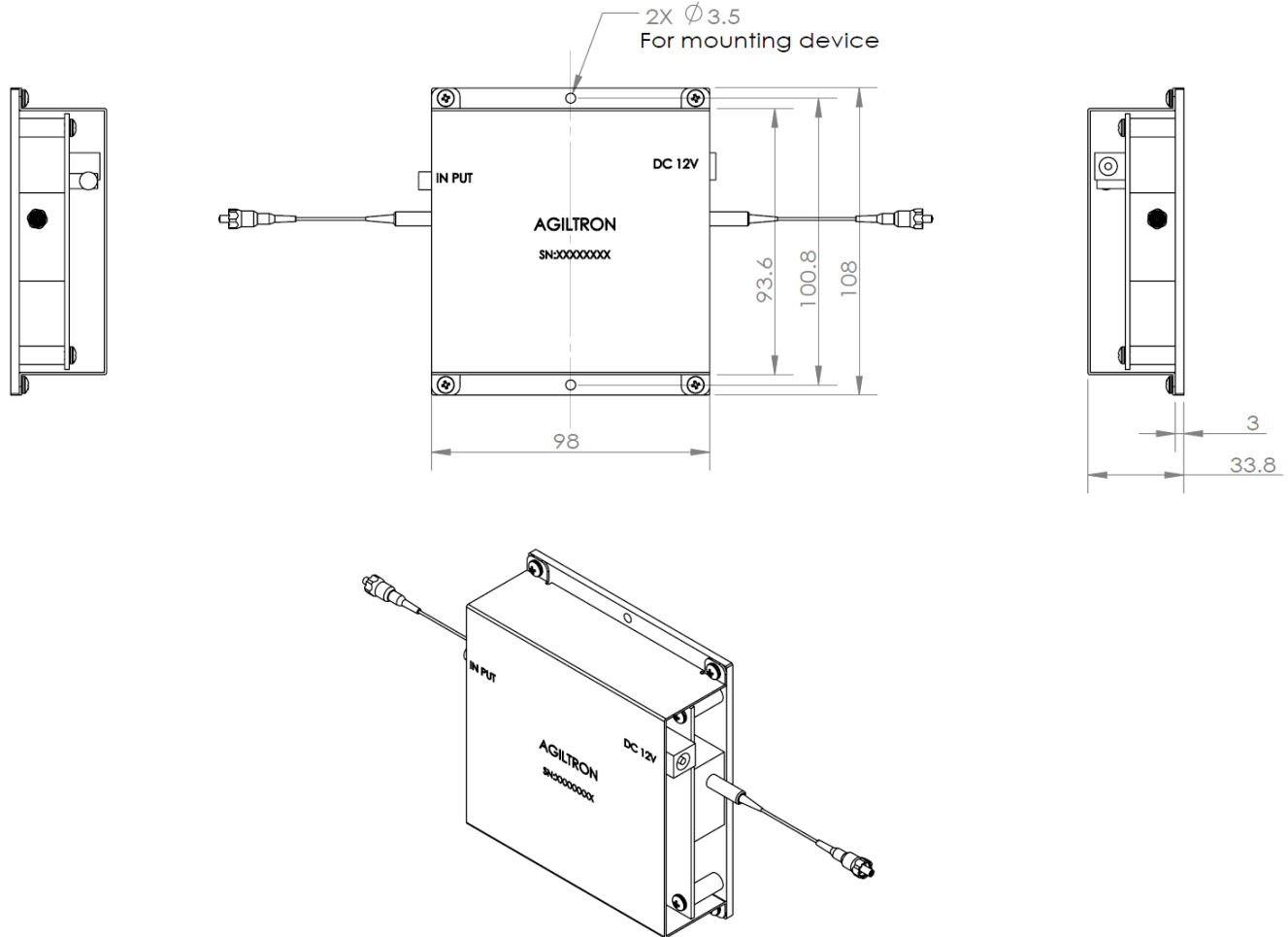

*Product dimensions may change without notice. This is sometimes required for non-standard specifications.

Typical 20KH Switching Between Two Ports

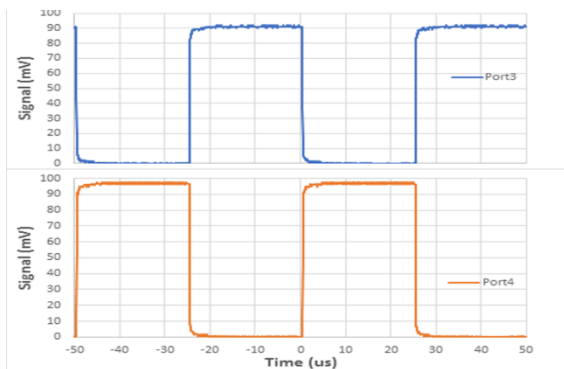

Output Ports Intensity Exchange During Switching

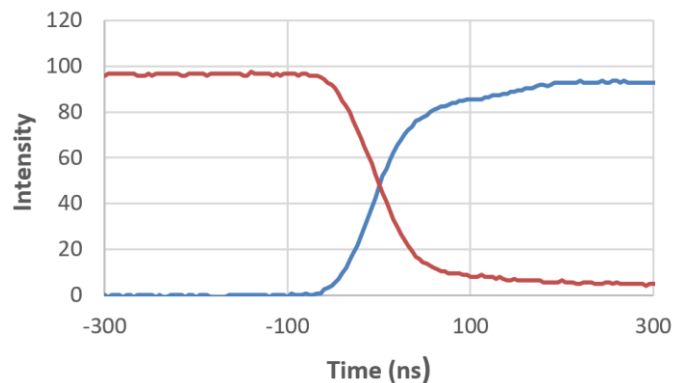

NanoSpeed™ 30dB Extinction, Low Drift 1x1 Fiber Optical Switch

1dB Loss, SMF, PMF, High Power, Bidirectional

(Protected by U.S. patent 7,403,677B1 and pending patents)



DATASHEET

Ordering Information

Prefix	Type	Wavelength ^[1]	Optical Power ^[2]	Configuration	Max Frequency	Fiber Type	Fiber Cover	Fiber Length	Connector	Benchtop
NSS3-	1x1 = 1	1060nm = 1 L Band = 2 1310nm = 3 1410nm = 4 1550nm = 5 980nm = 9 850nm = 8 780nm = 7 650nm = 6 Special = 0	Standard = 1 5W = 2 10W = A 15W = C 20W = D Special = 0	Transparent = A Opaque = B	20kHz = 2 50kHz = 5 Special = 0	SMF-28 = 1 HI1060 = 2 HI780 = 3 PM1550 = 5 PM980 = 9 PM850 = 8 SM600 = 6 PM630 = 4 Special = 0	Bare fiber = 1 0.9mm tube = 3 Special = 0	0.25m = 1 0.5m = 2 1.0 m = 3 Special = 0	None = 1 FC/PC = 2 FC/APC = 3 SC/PC = 4 SC/APC = 5 ST/PC = 6 LC/PC = 7 Duplex LC/PC = 8 LC/APC = 9 E2000 APC = A LC/UPC = U Special = 0	None = 1 Benchtop = B

[1]. Center wavelength. The high power switch isn't available for the wavelength shorter than 960nm.

[2]. Regular connectors cannot handle high power. Please contact us for Agiltron's unique high-power connectors.

* This unit comes with an integrated driver, and a power supply is included.

Red color indicates special order

Note:

- PM1550** fiber works well for **1310nm**
- Opaque** – light is blocked without applying a voltage
- Transparent** – light goes through without applying a voltage

Benchtop Box Mechanical Dimension

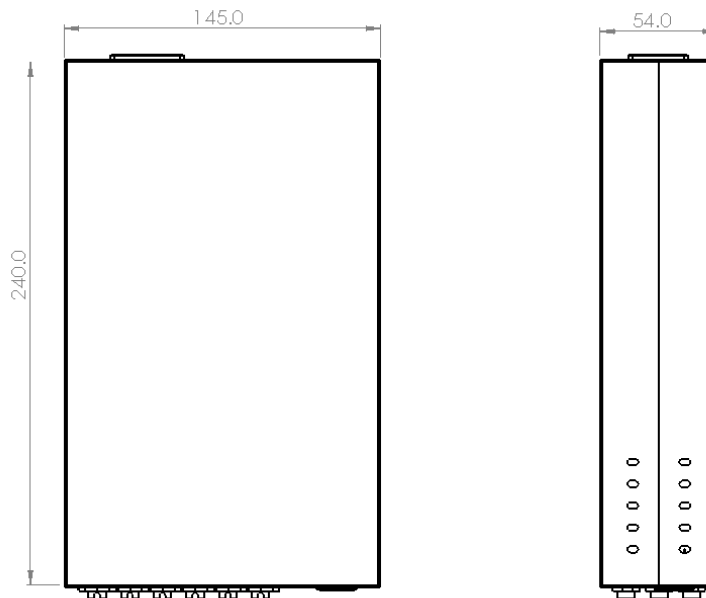

*Product dimensions may change without notice. This is sometimes required for non-standard specifications.

Optical Power Handling vs Wavelength For Single-Mode Fibers

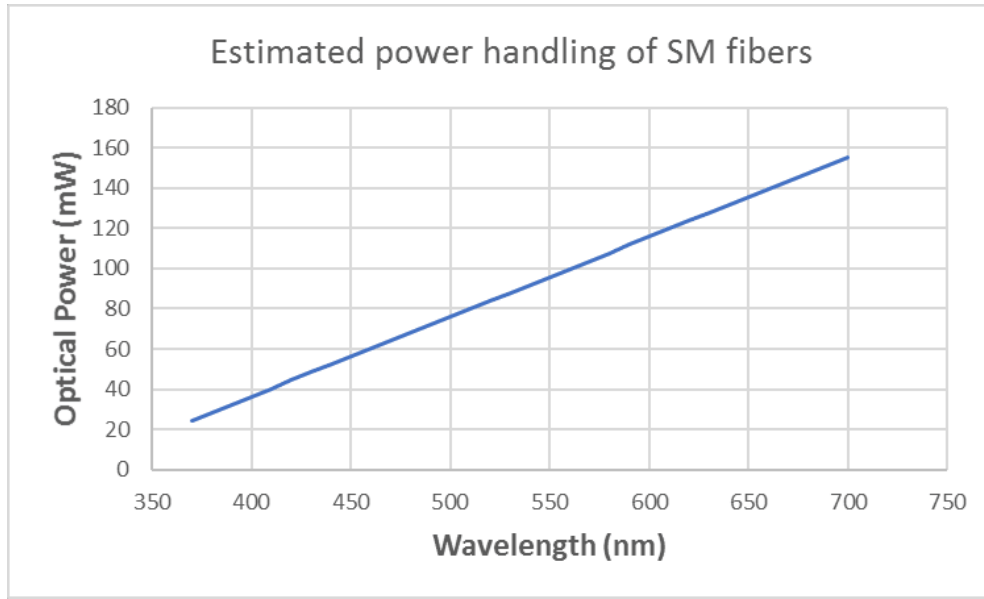

Typical On/Off Ratio (dB) vs Wavelength

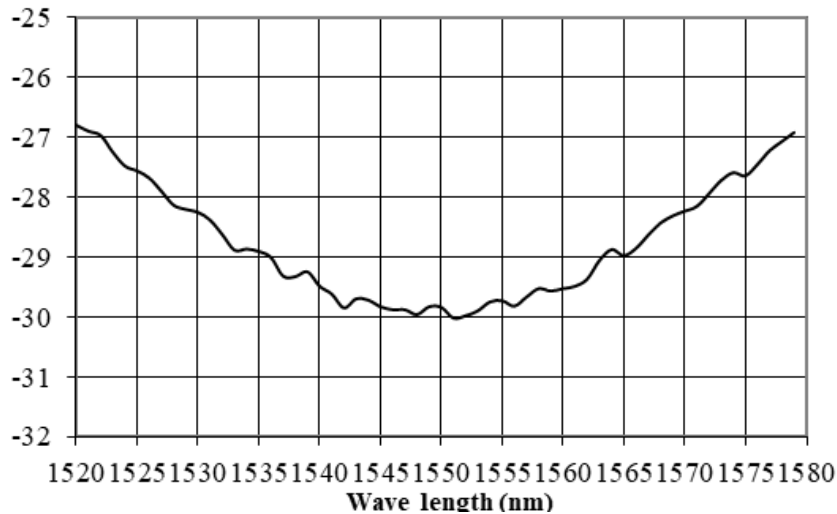

NanoSpeed™

30dB Extinction, Low Drift 1x1 Fiber Optical Switch

1dB Loss, SMF, PMF, High Power, Bidirectional

(Protected by U.S. patent 7,403,677B1 and pending patents)



DATASHEET

Application Notes

Fiber Core Alignment

Note that the minimum attenuation for these devices depends on excellent core-to-core alignment when the connectors are mated. This is crucial for shorter wavelengths with smaller fiber core diameters that can increase the loss of many decibels above the specification if they are not perfectly aligned. Different vendors' connectors may not mate well with each other, especially for angled APC.

Fiber Cleanliness

Fibers with smaller core diameters (<5 μm) must be kept extremely clean, contamination at fiber-fiber interfaces, combined with the high optical power density, can lead to significant optical damage. This type of damage usually requires re-polishing or replacement of the connector.

Maximum Optical Input Power

Due to their small fiber core diameters for short wavelength and high photon energies, the damage thresholds for device is substantially reduced than the common 1550nm fiber. To avoid damage to the exposed fiber end faces and internal components, the optical input power should never exceed 20 mW for wavelengths shorter 650nm. We produce a special version to increase the handling by expanding the core side at the fiber ends.